

SRX01 Series

Countersink Depth Gage

TRULOK
PRECISION MEASURING INSTRUMENTS



RADIUS PROBE

A high precision digital gage for quick and accurate measurement of the countersink depth. The SRX01 gages have a radius type probe that contacts the inside wall of the countersink (see detail). The radius probe is designed to contact the bottom area of the countersink and can check a wide range of countersunk holes for virtually any flush head fastener—limited only by the hole diameter through. This gage can be used to set drill cages or micro-stops. The countersink angle can be calculated by using the SRX01 Countersink Depth Gage in conjunction with the SRX00 or SRX02 Countersink Diameter Gage.

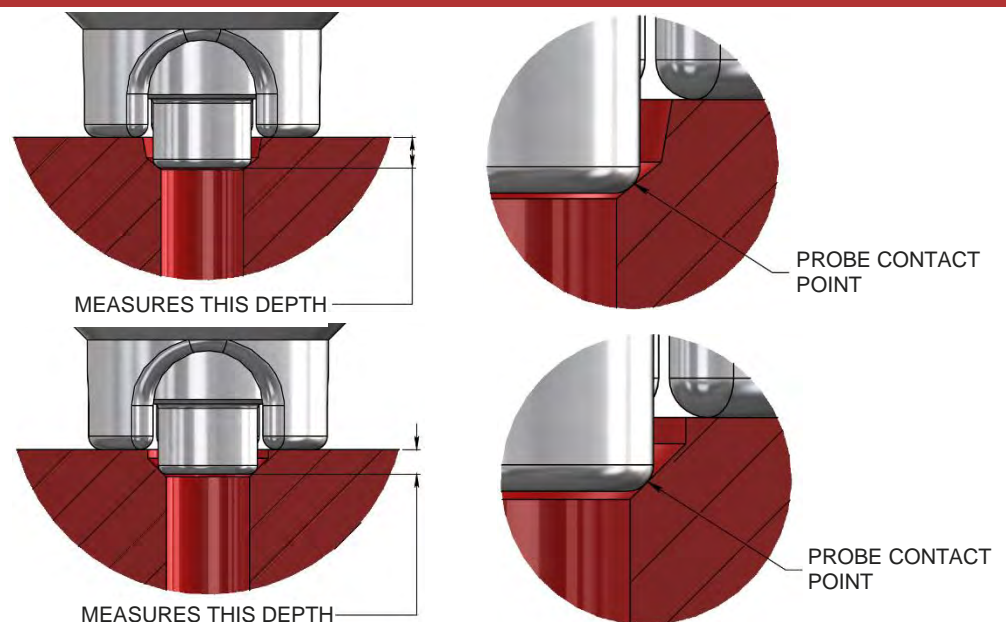

FEATURES

- Measuring accuracy .00025 inch (.006mm)
- Direct contact inside the countersink walls
- Direct reading, no calculations or charts necessary
- Large base configurations available for curved surfaces
- Accurate, repeatable, and reproducible
- SPC ready via data port cable
- Ease of use with minimal training
- Eliminate costly rework
- Gage and set block calibrated to NIST traceable standards
- Unique serial numbers on gages, set blocks, and indicators
- Components made of heat treated, wear-resistant tool steels and microfinished to ensure accurate and trouble-free operation



DIGITAL INDICATOR'S FEATURES

- LCD display with rotating bezel
- Inch/mm mode toggle capable
- SPC data output ready via data port
- Upper and lower tolerance capable
- Wireless transmission & Bluetooth compatible

ORDERING INFORMATION:

SRX01 - XXX - XX

BODY STYLE:

- 7 = KNURLED, SLIM
- 8 = KNURLED TYPE
- 9 = FLANGE STYLE

GAGE NUMBER:

ASSIGNED IN SEQUENCE BY TRIO

DIAMETER SIZE:

CAN BE THE SAME AS THE FASTENER SIZE, THE EXACT DECIMAL SIZE OR ANY NUMBER

BASE STYLE:

- T = TRIPOD
- B = BIPOD
- Q = QUADPOD

BODIES:



700



800



900

BASES:



TRIPOD

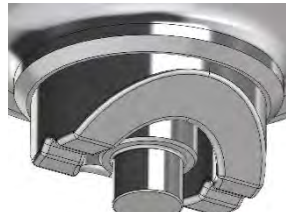

BIPOD



QUADPOD

TRULOK® gages are built to your exact specifications and parameters. Please supply us with the following data:

Countersink angle	Countersink depth	Hole/Bore Ø	Countersink Ø	Standard countersink? [YES/NO]	Counterbore countersink? [YES/NO]

- Fastener part number | specification: _____
- Surface curvature: _____
- Size, thickness & position of any Drilling jig or fixture to measure through: _____